

POWER-Skru™ Large Diameter Concrete Screw



Description

The POWER-Skru Large Diameter Concrete Screw is a **high-strength screw anchor** with self-tapping threads that offer a unique undercutting design for anchoring into concrete and masonry. No secondary setting is needed. The POWER-Skru Large Diameter Concrete Screw **provides high-strength performance with low installation torque**. A heavy-duty mechanically-galvanized finish is available to enhance corrosion resistance.

Key Features & Benefits

- ▶ Electroplated zinc or heavy-duty **mechanically galvanized** finish available
- ▶ Heat treatment provides surface and core hardness
- ▶ One-piece design with finished washer head
 - No nuts and washers to assemble prior to installation
- ▶ Serrated head facilitates a positive lock between bolt and application surface for enhanced
 - Vibration and shock resistance
- ▶ Hardened, self-tapping threads feature a revolutionary undercutting design
 - Allows for immediate load application
 - Reduces required installation torque
- ▶ **Can be removed and reinstalled** – ideal for temporary anchoring applications and those requiring service
- ▶ Anchor length is stamped on head to ease identification pre- and post-installation
- ▶ Easier and faster installation than mechanical expansion anchors
 - **Bolt Size is Hole Size®**
 - Prepare hole with lower-cost ANSI B212.15 standard bit – **no metric or off-size bits needed**
- ▶ Less spacing and edge distance requirements - no expansion forces applied to base material

Applications

- ▶ Racking
- ▶ Railing Sill Plates
- ▶ Stadium Seating
- ▶ Tilt-Up Braces
- ▶ Formwork
- ▶ Anchoring Equipment

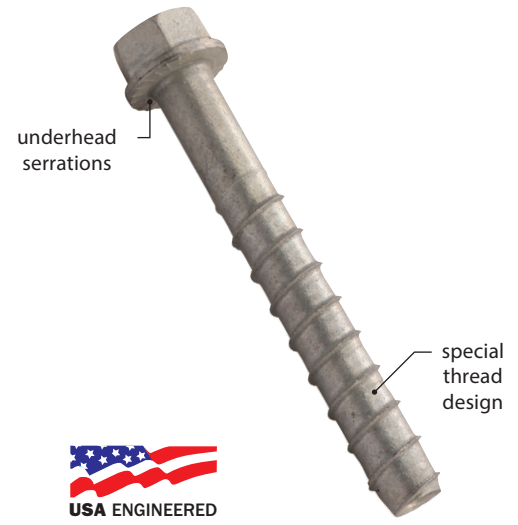

Specifications, Listings and Approvals

Diameters: 1/4" – 3/4"

Anchor Body: Heat-treated carbon steel

Finish:

- Electroplated zinc-plated to ASTM B633, Type III, SC1 (**1/4" dia. only**)
- Mechanically galvanized to ASTM B695, Class 65, Type 1 (**all sizes**)

Threads: Self-tapping threads with special undercutting design

Head Style: One-piece hex washer head with locking serrations

Application Materials: Normal weight concrete, lightweight concrete, solid masonry; may be suitable for hollow masonry

Specs: Tested in accordance with ASTM E488

Installation Information

Installation Instructions

1. Using the proper size carbide bit, drill a pilot hole at least 1/2" deeper than the desired anchor embedment.
2. Clean the hole using a nylon brush and compressed air.
3. **Solid Concrete:** Using an electric impact wrench, or socket wrench, insert anchor through the fixture into hole and tighten anchor until fully seated. If using an electric impact wrench, start on light torque setting to prevent over-torquing or damaging threads.
- 3b. **Concrete Block (CMU)** Using a socket wrench insert anchor into hole and hand tighten anchor until fully seated. Do not use an impact wrench for installation into CMU walls.

NOTE: Always wear safety glasses.

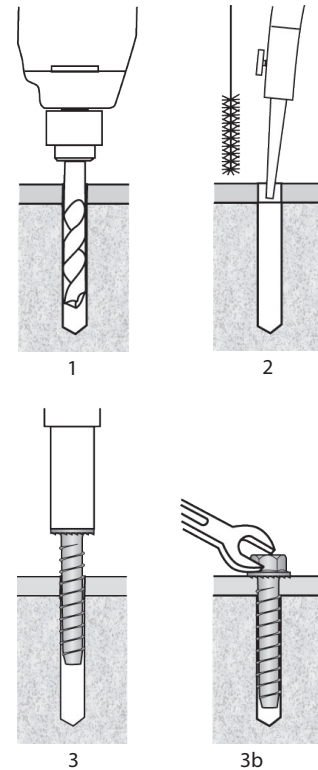

Installation Data

Anchor Dia. (in.)	Drill Bit Dia. (in.)	Installation Torque Approx. (ft-lbs.)	Wrench Socket Size (in.)	Min. Baseplate Clearance Hole (in.)	Critical Edge Distance (in.)	Min. Edge Distance (in.)	Critical Spacing (in.)	Min. Spacing (in.)	Head & Washer Height (in.)	Washer Outer Dia., Approx. (in.)
1/4	1/4	8	7/16	3/8	2	3/4	3	1	1/4	1/2
3/8	3/8	25	9/16	1/2	3	1-1/8	4-1/2	1-1/2	3/8	3/4
1/2	1/2	55	3/4	5/8	4	1-1/2	6	2	31/64	1
5/8	5/8	95	15/16	3/4	5	1-7/8	7-1/2	2-1/2	19/32	1-5/32
3/4	3/4	150	1-1/8	7/8	6	2-1/4	9	3	45/64	1-3/8

Performance Data

Ultimate and Allowable Loads (lbs.) – Normal-Weight Concrete

Anchor Dia. (in.)	Drill Bit Dia. (in.)	Embedment Depth (in.)	Allowable				Ultimate			
			3,000 psi		6,000 psi		3,000 psi		6,000 psi	
			Tension	Shear	Tension	Shear	Tension	Shear	Tension	Shear
1/4	1/4	1-3/16	190	428	258	670	760	1710	1030	2680
		2-1/2	600	443	863	713	2400	1770	3450	2850
3/8	3/8	2	920	890	1063	2060	3680	3560	4250	8240
		3-1/2	2085	2048	2788	3008	8340	8190	11150	12030
1/2	1/2	2	853	1088	1190	2268	3410	4350	4760	9070
		3-1/2	2190	2235	3008	3668	8760	8940	12030	14670
5/8	5/8	2-1/2	873	1190	1173	3163	3490	4760	4690	12650
		3-1/2	2325	2390	3340	5915	9300	9560	13360	23660
3/4	3/4	2-1/2	1078	1570	1760	3535	4310	6280	7040	14140
		5-3/4	3290	3960	6753	7933	13160	15840	27010	31730

Note: The data presented in this table is based on independent laboratory testing at critical anchor spacing and edge distance

*Tested in accordance with ASTM E488

*Allowable load capacities are calculated using an applied safety factor of 4:1

Load Adjustment Factors

Spacing – Tension

Anchor Dia.	1/4	3/8	1/2	5/8	3/4	
Critical Spacing S_{cr}	3	4-1/2	6	7-1/2	9	
Min. Spacing S_{min}	1	1-1/2	2	2-1/2	3	
Actual Spacing S_{act}	1	0.50	-	-	-	
	1-1/2	0.63	0.50	-	-	
	2	0.77	0.57	0.50	-	
	2-1/2	0.89	0.66	0.56	0.50	
	3	1.00	0.74	0.62	0.56	0.50
	4-1/2	-	1.00	0.80	0.76	0.63
	6	-	-	1.00	0.87	0.77
	7-1/2	-	-	-	1.00	0.90
9	-	-	-	-	1.00	

For tension anchor loads (lbs.) the critical spacing is equal to 12 anchor diameters at which the anchor achieves 100% of load. Minimum spacing is equal to 4 anchor diameters at which the anchor achieves 50% of load.

Spacing – Shear

Anchor Dia.	1/4	3/8	1/2	5/8	3/4	
Critical Spacing S_{cr}	3	4-1/2	6	7-1/2	9	
Min. Spacing S_{min}	1	1-1/2	2	2-1/2	3	
Actual Spacing S_{act}	1	0.75	-	-	-	
	1-1/2	0.81	0.75	-	-	
	2	0.87	0.79	0.75	-	
	2-1/2	0.93	0.83	0.78	0.75	
	3	1.00	0.87	0.81	0.78	0.75
	4-1/2	-	1.00	0.90	0.86	0.80
	6	-	-	1.00	0.94	0.89
	7-1/2	-	-	-	1.00	0.95
9	-	-	-	-	1.00	

For Shear anchor loads the critical spacing (s_{cr}) is equal to 12 anchor diameters at which the anchor achieves 100% of load. Minimum spacing (s_{min}) is equal to 4 anchor diameters at which the anchor achieves 75% of load.

Load Adjustment Factors

Edge Distance – Tension

Anchor Dia.	1/4	3/8	1/2	5/8	3/4	
Critical Edge Dist. C_{cr}	2	3	4	5	6	
Min. Edge Dist. C_{min}	3/4	1-1/8	1-1/2	1-7/8	2-1/4	
Actual Edge Dist. C_{act}	3/4	0.70	-	-	-	
	1-1/8	0.78	0.70	-	-	
	1-1/2	0.86	0.76	0.70	-	
	1-7/8	0.97	0.82	0.74	0.70	
	2	1.00	0.85	0.76	0.72	
	2-1/4	-	0.90	0.80	0.76	0.70
	3	-	1.00	0.89	0.81	0.75
	4	-	-	1.00	0.91	0.84
	5	-	-	-	1.00	0.92
6	-	-	-	-	1.00	

For tension anchor loads the critical edge distance (C_{cr}) is equal to 8 anchor diameters at which the anchor achieves 100% of load. Minimum edge distance (C_{min}) is equal to 3 anchor diameters at which the anchor achieves 70% of load.

Edge Distance – Shear

Anchor Dia.	1/4	3/8	1/2	5/8	3/4	
Critical Edge Dist. C_{cr}	3	4-1/2	6	7-1/2	9	
Min. Edge Dist. C_{min}	3/4	1-1/8	1-1/2	1-7/8	2-1/4	
Actual Edge Dist. C_{act}	3/4	0.15	-	-	-	
	1-1/8	0.29	0.15	-	-	
	1-1/2	0.42	0.25	0.15	-	
	1-7/8	0.57	0.35	0.23	0.15	
	2-1/4	0.72	0.46	0.31	0.21	0.15
	3	1.00	0.62	0.45	0.32	0.25
	4-1/2	-	1.00	0.75	0.56	0.46
	6	-	-	1.00	0.77	0.65
	7-1/2	-	-	-	1.00	0.84
9	-	-	-	-	1.00	

For shear anchor loads the critical edge distance (C_{cr}) is equal to 12 anchor diameters at which the anchor achieves 100% of load. Minimum edge distance (C_{min}) is equal to 3 anchor diameters at which the anchor achieves 15% of load.



Order Information



Zinc Electroplated, Heat-Treated Carbon Steel					
Catalog No.	Anchor Size (in.)	Drill Bit Dia. (in.)	Baseplate Clearance Hole (in.)	Box Quantity	Carton Quantity
ATEZ1413	1/4 x 1-3/4	1/4	3/8	100	800
ATEZ1421	1/4 x 2-1/4	1/4	3/8	100	800
ATEZ1430	1/4 x 3	1/4	3/8	100	800

Mechanically Galvanized, Heat-Treated Carbon Steel					
Catalog No.	Anchor Size (in.)	Drill Bit Dia. (in.)	Baseplate Clearance Hole (in.)	Box Quantity	Carton Quantity
ATEZG1413	1/4 x 1-3/4	1/4	3/8	100	800
ATEZG1421	1/4 x 2-1/4	1/4	3/8	100	800
ATEZG1430	1/4 x 3	1/4	3/8	100	800
ATEZG3830	3/8 x 3	3/8	1/2	50	400
ATEZG3840	3/8 x 4	3/8	1/2	50	400
ATEZG3850	3/8 x 5	3/8	1/2	25	200
ATEZG3860	3/8 x 6	3/8	1/2	25	200
ATEZG1230	1/2 x 3	1/2	5/8	20	160
ATEZG1240	1/2 x 4	1/2	5/8	20	160
ATEZG1250	1/2 x 5	1/2	5/8	20	160
ATEZG1260	1/2 x 6	1/2	5/8	20	160
ATEZG1270	1/2 x 7	1/2	5/8	20	160
ATEZG5840	5/8 x 4	5/8	3/4	10	80
ATEZG5850	5/8 x 5	5/8	3/4	10	80
ATEZG5860	5/8 x 6	5/8	3/4	10	80
ATEZG5870	5/8 x 7	5/8	3/4	10	80
ATEZG5880	5/8 x 8	5/8	3/4	10	40
ATEZG3440	3/4 x 4	3/4	7/8	10	80
ATEZG3450	3/4 x 5	3/4	7/8	10	80
ATEZG3460	3/4 x 6	3/4	7/8	10	60
ATEZG3470	3/4 x 7	3/4	7/8	5	30

COMING SOON! Large Diameter Concrete Screws: Type 316 Stainless Steel