

ROUND HEAD WOOD SCREWS														
Nominal Size	A		H		J		T		Dimensions of Recess				Phillips Driver Size	
	Head Diameter		Height of Head		Width of Slot		Depth of Slot		Diameter		Depth			Width
	Max	Min	Max	Min	Max	Min	Max	Min	Max	Min	Max	Min		Min
2	.162	.146	.069	.059	.031	.023	.048	.037	.114	.101	.064	.042	.018	1
4	.211	.193	.086	.075	.039	.031	.058	.044	.130	.117	.083	.063	.019	1
5	.236	.217	.095	.083	.043	.035	.063	.047	.154	.141	.074	.046	.027	2
6	.260	.240	.103	.091	.048	.039	.068	.051	.162	.149	.084	.056	.027	2
7	.285	.264	.111	.099	.048	.039	.072	.055	.170	.157	.092	.066	.028	2
8	.309	.287	.120	.107	.054	.045	.077	.058	.178	.165	.101	.075	.030	2
9	.334	.311	.128	.115	.054	.045	.082	.062	.186	.173	.110	.084	.030	2
10	.359	.334	.137	.123	.060	.050	.087	.065	.195	.182	.119	.093	.031	2
12	.408	.382	.153	.139	.067	.056	.096	.073	.249	.236	.125	.099	.032	3
14	.457	.429	.170	.155	0.75	.064	.106	.080	.265	.252	.142	.116	.034	3

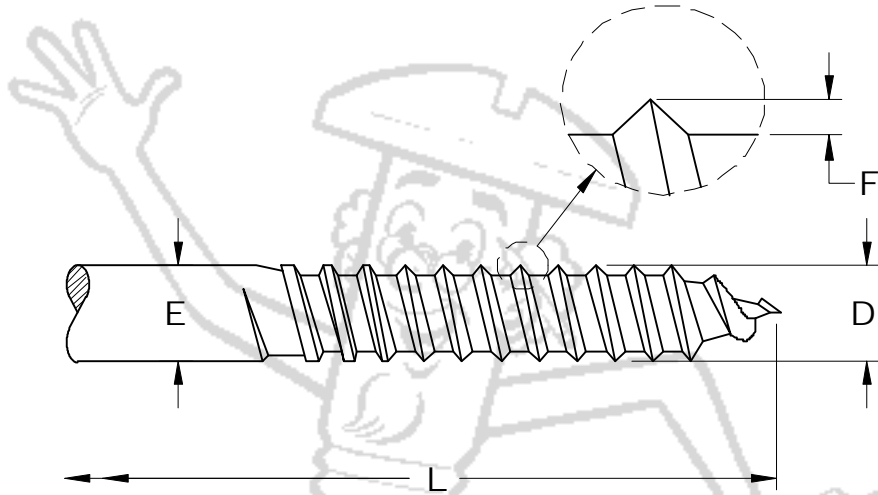

THREAD & BODY DIAMETERS FOR WOOD SCREWS - CUT THREAD							
Nominal Size or Basic Screw Diameter		Threads per Inch ($\pm 10\%$)	D		E		F
			Major Thread Diameter		Body Diameter (Cut Thread)		Thread Depth
			Max	Min	Max	Min	Min
2	.086	26	.090	.079	.090	.079	.010
4	.112	22	.116	.105	.116	.105	.016
5	.125	20	.129	.118	.129	.118	.018
6	.138	18	.142	.131	.142	.131	.020
7	.151	16	.155	.144	.155	.144	.022
8	.164	15	.168	.157	.168	.157	.023
9	.177	14	.181	.170	.181	.170	.026
10	.190	13	.194	.183	.194	.183	.030
12	.216	11	.220	.209	.220	.209	.031
14	.242	10	.246	.235	.246	.235	.035